

REFRACTORIES

— FOR —

ALUMINUM



Global **Refractory** Solutions

6



ABOUT ALLIED



Allied Mineral Products is a world leader in the design and manufacture of monolithic refractories and precast shapes. With strong sales and service teams in the foundry, aluminum, steel, heat treat/forge and industrial markets, our success is based on our dedication to *Being There Worldwide with Refractory Solutions*.

Producing quality, consistent products is top priority at Allied and we have the products to meet your refractory needs. Our extensive product line includes innovative refractory technology and longstanding refractory alternatives.

Allied's focus on quality at every stage in the production process is unparalleled. A stringent raw material standard and global quality control testing before and after each batch is produced, provides customers with consistent products. We provide quick response times to any urgent request through flexible manufacturing systems at all our manufacturing facilities.

Global **Refractory** Solutions





RESEARCH & ENGINEERING

After gaining a detailed understanding of your specific needs, our team evaluates operating criteria and physical design parameters to create a detailed engineered design encompassing:

- Patented technologies
- Optimized product zoning
- Thermal models to optimize and validate designs
- Proven safety lining system designs
- Unique installation properties and techniques
- Leading edge refractory system designs

We're focused on developing new products, improving existing products and perfecting installation techniques. Our product development and testing is conducted in our state of the art research and technology center. We have an on-site gunning and shotcreting lab allowing extensive testing of installation properties.

As an innovative, technology-driven supplier we're devoted to providing customized refractory solutions for various industry operations. We offer a wide variety of high performance refractory products with superior raw material quality.

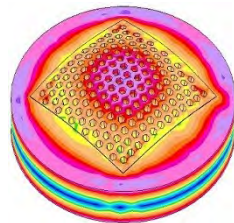
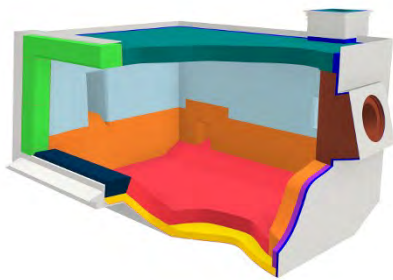

FEA Thermal Analysis



Flow Testing

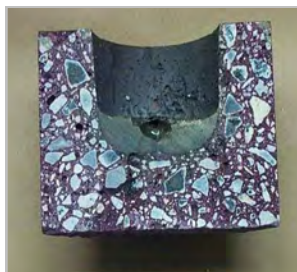

Contact Tests



Strength Tests





PRODUCT INNOVATIONS



QUICK-FIRE®

QUICK-FIRE® is a two-component technology that utilizes a liquid phosphate bonding system that improves performance and can drastically reduce downtime. QUICK-FIRE® can be used as a veneer on top of an existing lining, or as a repair for a full lining thickness.

Product Benefits

- Rapid dry-out characteristics
- Designed to bond to existing refractory
- Fast setting properties
- Superior non-wetting characteristics
- Excellent thermal shock resistance
- Available in gunning, casting and troweling formulations

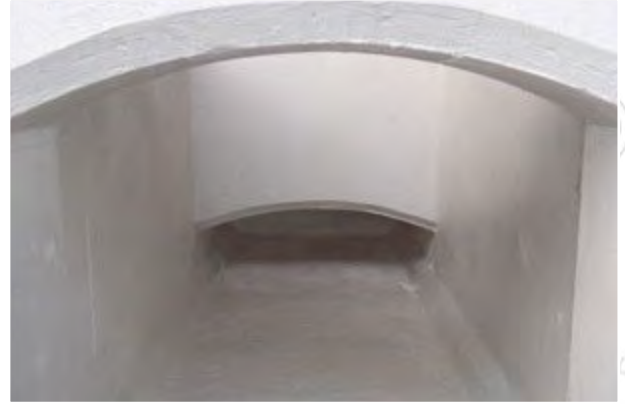

QUICK-FIRE® ONE

QUICK-FIRE® ONE is a line of single-component, rapid turnaround products that set faster than most cement bonded castables. QUICK-FIRE® ONE products require only a water addition for mixing instead of liquid phos acid. This single-component system allows the product to ship like typical refractory materials without the need for special transportation requirements.

- Rapid dry-out characteristics
- Designed to bond to existing refractory
- Fast setting properties
- Superior non-wetting characteristics
- Excellent thermal shock resistance
- Abrasion resistance
- Available in gunning, casting and troweling formulations





PRODUCT INNOVATIONS

NANO-TEK[®] AL, NANO-GUN[™] AL & NANO-PUMP[™] AL

NANO-TEK[®] AL is a line of colloidal silica bonded refractories for aluminum applications. The products can be vibrated, pumped or shotcreted. NANO-GUN[™] AL is the gunning version of NANO-TEK[®] AL and NANO-PUMP[™] AL is the pumping version of NANO-TEK[®] AL. All product families provide good strengths and thermal shock resistance and adhere well to existing refractories.

Product Benefits

- Accelerated heat-up
- Quick turnaround
- Excellent thermal shock resistance
- Abrasion resistance
- No cement
- Good mechanical strengths



MATRIFLO

MATRIFLO products are a specialty line of high alumina, low cement castables designed for aggressive aluminum alloys.

Product Benefits

- Superior corrosion resistance
- High strength
- Excellent non-wetting properties
- Resistance to salt flux
- Thermal shock resistance
- Abrasion resistance

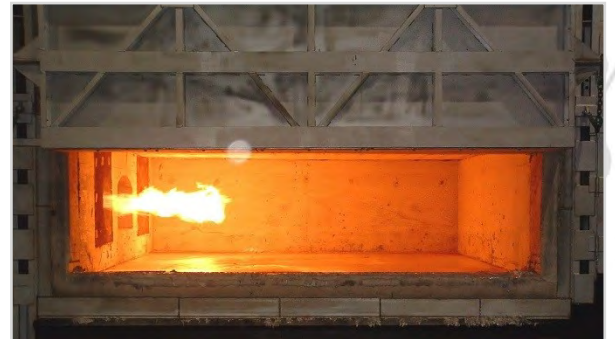

REDIGUN

REDIGUN is a family of gunning plastic. The plastic gunning process provides a high-density monolithic lining comparable to rammed plastic at a much faster and consistent installation rate.

- Used for repairs or for full lining thickness installations
- Low rebound
- Quick and consistent installation
- Consistent optimal density
- Faster dry-out compared to low-cement castables

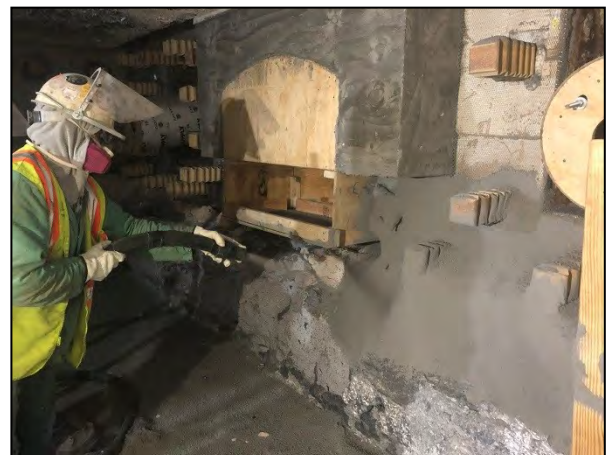



REVERBERATORY



ROOF

- MATRIPUMP 50
- MATRIPUMP AR 61
- NANO-TEK® 65 HS
- NANO-TEK® 70
- TUFF-FLO 608

UPPER SIDE WALLS

- MATRIPHOS 85AC
- MATRIPUMP AR 61
- NANO-TEK® 70
- QUICK-FIRE® 88
- QUICK-FIRE® ONE 86

BURNERS

- KAST TECH® 60
- LCF 798A
- MATRIPHOS 85AC
- NANO-TEK® 70
- QUICK-FIRE® 88
- QUICK-FIRE® ONE 86

JAMBS / LINTELS

- ARMORMAX® 70SR
- NANO-TEK® 65-3 SiC HS
- NANO-TEK® 70
- QUICK CAST® 62
- QUICK-FIRE® 88
- QUICK-FIRE® ONE 86
- TUFF-FLO 608

RAMP / SILL

- MATRIFLO 70 ACX COARSE
- MATRIFLO 85 ACX
- MATRIFLO AL C
- MATRIFLO SiC 6 COARSE
- MATRIPUMP 608 AL
- NANO-TEK® 75 18SiC AL HS
- QUICK-FIRE® 90
- QUICK-FIRE® ONE 83 ABR

SUBHEARTH

- BETAMAX® 24 LT
- MATRICAST 2600 AC
- MATRIGUN 25 ACX
- MATRIPUMP 45 AL
- NANO-PUMP™ 45 AL HS

HEARTH

- MATRIFLO 80 ACX PUMP
- MATRIFLO 85 ACX
- MATRIPUMP 63 ACX
- MATRIPUMP 70 ACX
- NANO-TEK® 80 AL HS
- QUICK CAST® 61 ACX
- QUICK-FIRE® ONE 86

LOWER SIDEWALLS

- MATRIFLO 80 ACX PUMP
- MATRIFLO 85 ACX
- NANO-TEK® 80 AL HS
- QUICK-FIRE® 88
- QUICK-FIRE® ONE 86

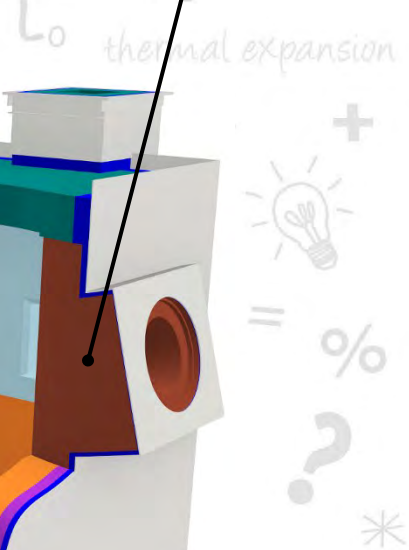
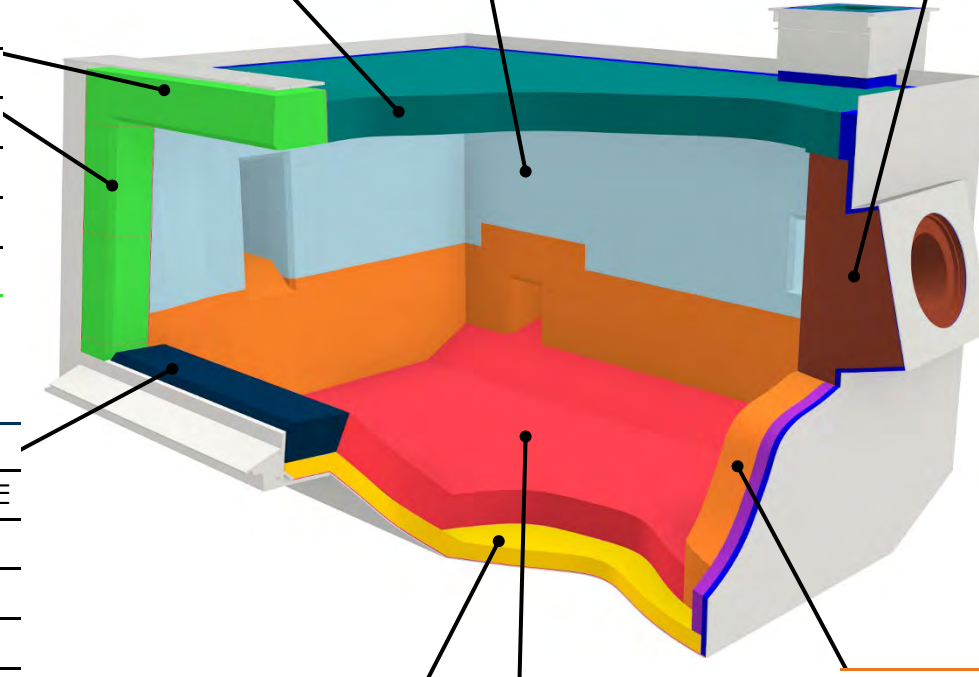



process global
STACKMELTER

refractory



Σ

research



$AL = \alpha, AT$



STACK

ARMORMAX® 70 SR (upper)

MATRIFLO 80 ACX PUMP

MATRIFLO 85 ACX

MATRIFLO 93 AC

QUICK CAST® 61 ACX

BURNERS

KAST TECH® 60

LCF 798A

MATRIPHOS 85AC

NANO-TEK® 70

QUICK-FIRE® 88

QUICK-FIRE® ONE 86

ROOF

MATRICAST 3110C

MATRIPUMP 50

MATRIPUMP AR 61

NANO-TEK® 70

SIDEWALLS

MATRIFLO 80 ACX PUMP

MATRIFLO 85 ACX

MATRIFLO 93 AC

WAM® AL II

WAM® AL II HD

WAM® AL II HDF

WAM® AL III

WAM® AL III HD

HEARTH & WALLS

MATRICAST 70 AC

QUICK CAST® 61 ACX

QUICK-FIRE® 88

WAM® AL II

WAM® AL III

BULL NOSE

ARMORMAX® 70 AC

QUICK CAST® 81 ACX

HEARTH / RAMP

MATRIFLO 80 ACX PUMP

MATRIFLO 85 ACX

MATRIFLO 93 AC

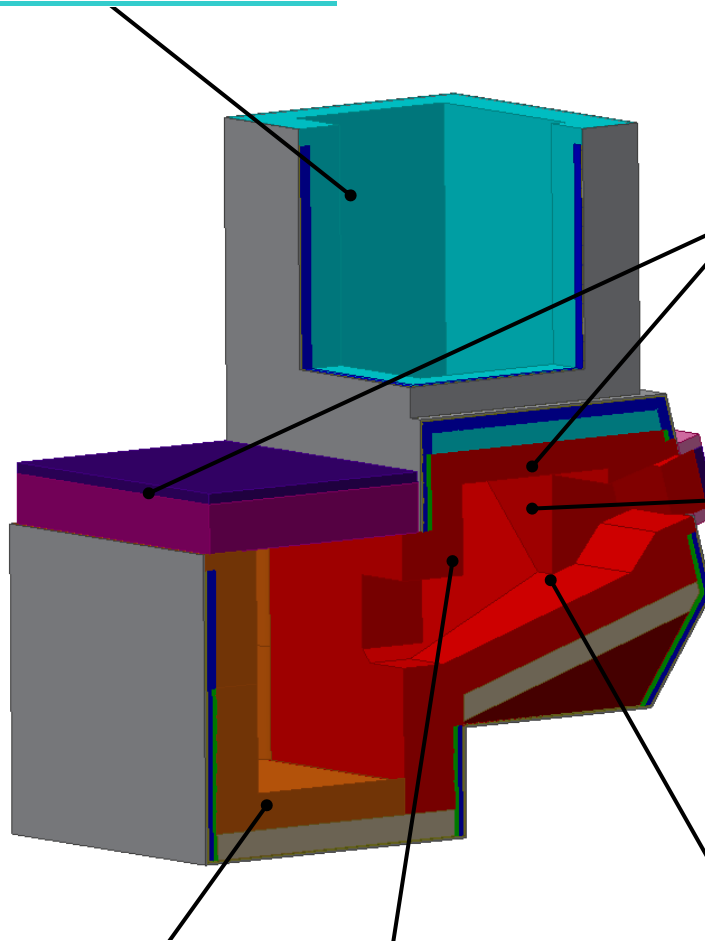

in our
element

DIE CASTING HOLDER

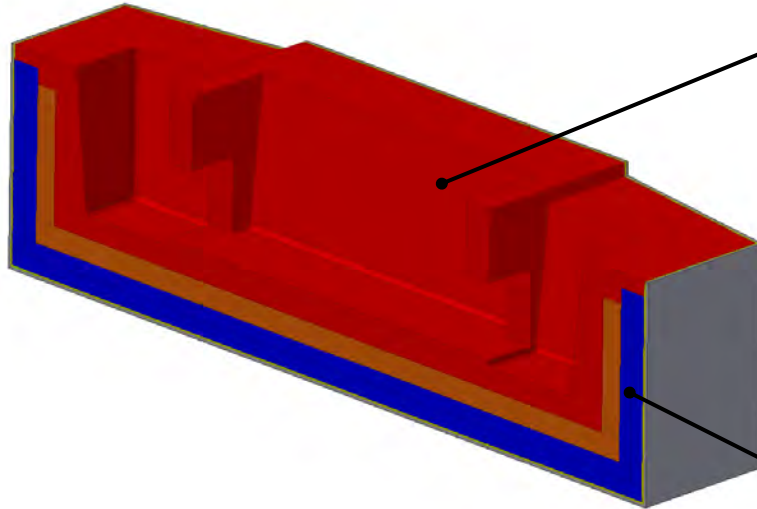

FURNACE LINING

MATRICAST 70 AC

MATRIFLO 85 ACX

MATRIPUMP 63 ACX

QUICK-FIRE® 88

QUICK-FIRE® ONE 86

WAM® AL II

WAM® AL III

SAFETY LINING

BETAMAX® 24 LT

BETAMAX® HS LT

DRI-LITE® 79AL-M

ROTARY

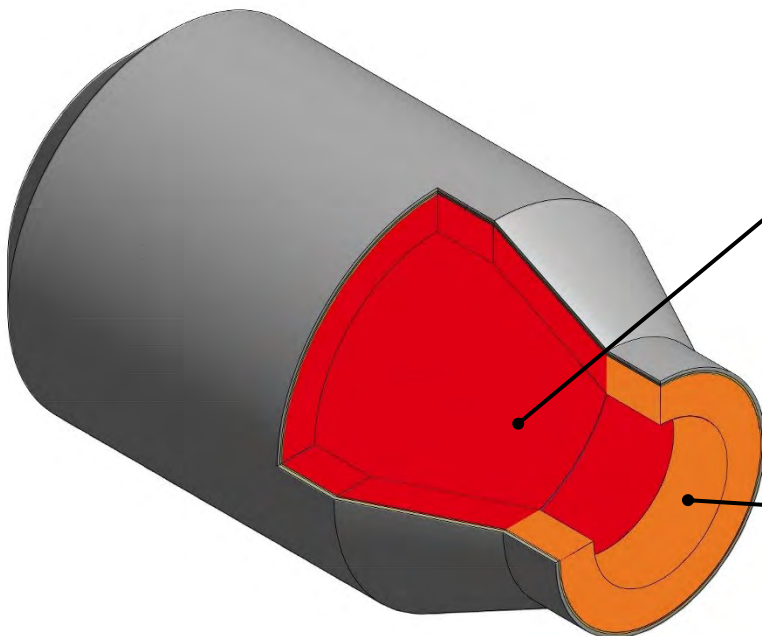

FURNACE LINING

MATRIPUMP 608 AL

NANO-TEK® 60 AL HS

QUICK CAST® 61 ACX

NOSE RING

ARMORMAX® 70 SR

MATRICAST 60 SiC

MATRICAST 82 SiC

MATRIPUMP 608 AL

NANO-TEK® 75 18SiC AL HS

QUICK CAST® 80 SiC FINE



CORELESS

refractory

$$\frac{\Delta L}{L_0} = \alpha_L \Delta T$$

thermal expansion

- SPOUT**
- MINRO-AL[®] PLASTIC A76
- MINRO-AL[®] PLASTIC A85
- PRECAST SHAPES
- QUICK-FIRE[®] 88
- QUICK-FIRE[®] ONE 86

- COVER**
- MINRO-FIRE CAST F80
- TUFF-FLO 50

- SLIP PLANE MATERIALS**
- GM40SRP
- MINRO-WEAVE CLOTH
- SINTERFOIL 50
- VAPORSHIELD

- STRUCTURAL COMPONENTS**
- PRECAST SHAPES
- QUICK CAST[®] 62
- TUFF-FLO 50

- WORKING LINING**
- DRI-VIBE[®] 520A
- DRI-VIBE[®] 522A-FR
- DRI-VIBE[®] 558A-FR
- PRECAST CRUCIBLES

- CRUCIBLE BACK-UP**
- DRI-VIBE[®] 291A
- DRI-VIBE[®] 88A NB

- WORKING LINING COATINGS**
- MATRIKOTE 90 AC
- MINRO-Z WASH Z77
- WASH 148A

- GROUT**
- COIL-CAST 97A
- GROUT 163 ACF
- GROUT 563A
- GROUT 663A

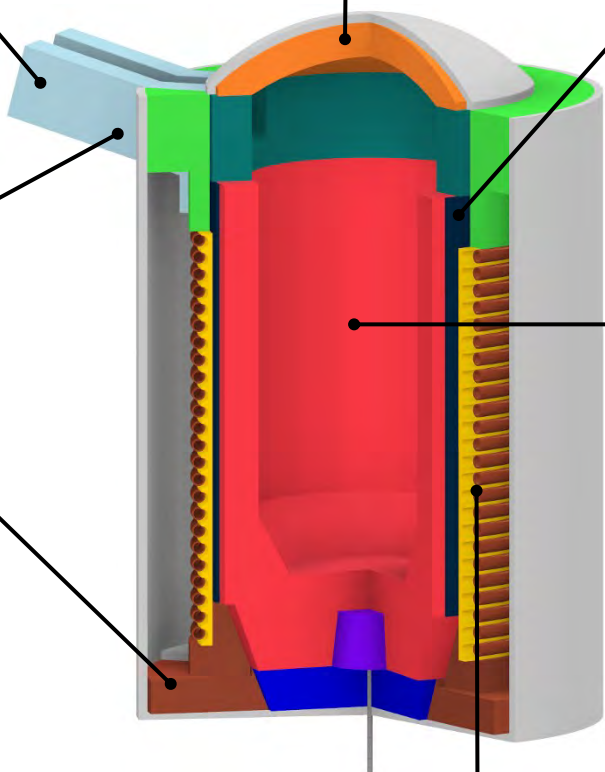



process
global
CHANNEL

refractory
research

COVER

INSULMIX® 33100

MATRIPUMP 50

MINRO-FIRE CAST F80

RECIEVER / SPOUT

MATRIFLO 80 ACX PUMP

MATRIFLO 85 ACX

MATRIFLO SiC 6

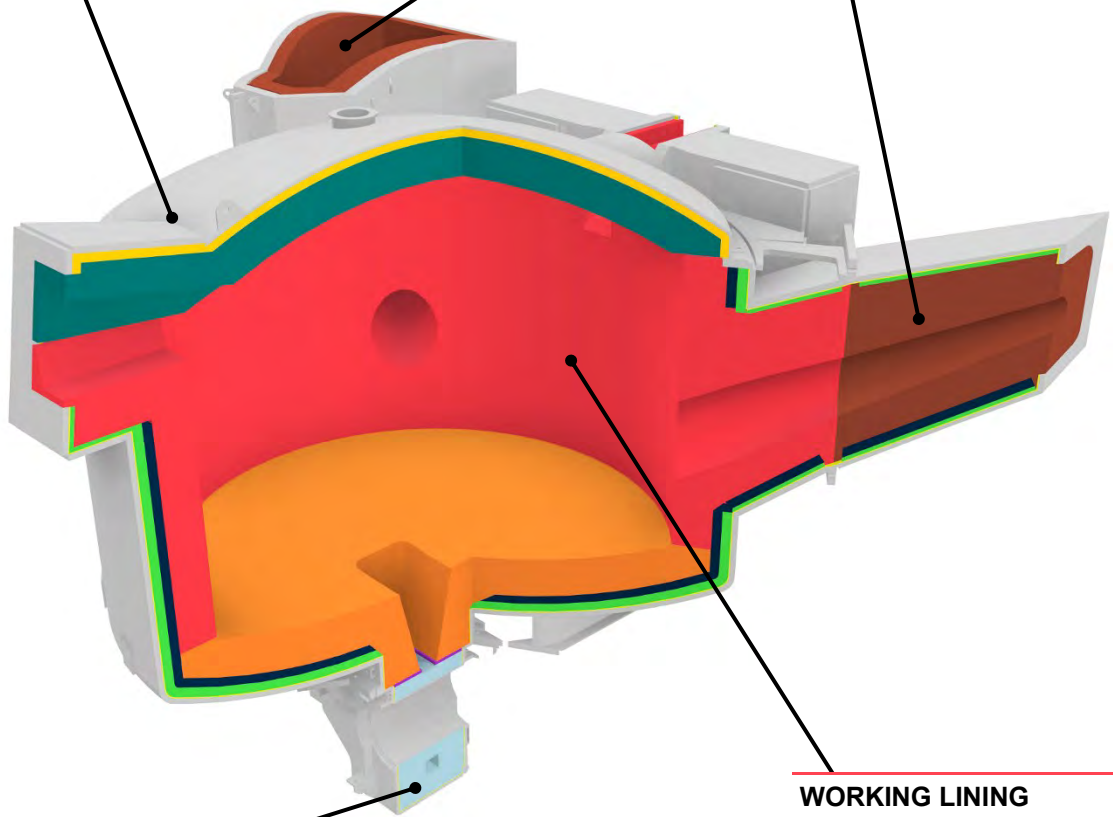

INDUCTOR

DRI-VIBE® 522A-FR

DRI-VIBE® 558A-FR

WORKING LINING

MATRIFLO 80 ACX PUMP

MATRIFLO 85 ACX

QUICK CAST® 61 ACX

pansion
+%
?*SEARCH





LAUNDERS/TROUGHS TRANSFER LADLES

HEATED LAUNDRER

WORKING LINING

MATRIFLO 85 ACX
QUICK CAST® 61 ACX
QUICK-FIRE® 88
QUICK-FIRE® ONE 86
WAM® AL II
WAM® AL III

BACK-UP LINING

BETAMAX® 24 LT
DRI-LITE® 79 AL-M

COVER

BETAMAX® 26 LT
BETAMAX® HS LT

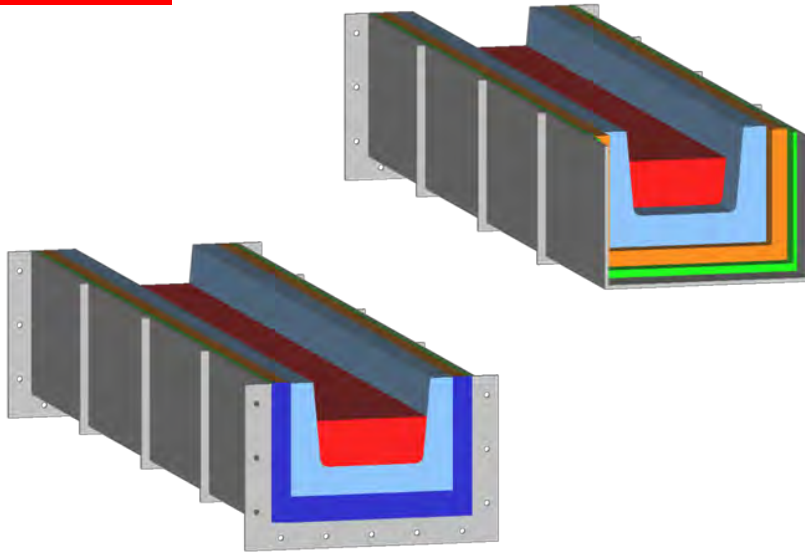

UNHEATED LAUNDRER

BACK-UP LINING

DRI-LITE® 65 A-L
DRI-LITE® 79 AL-M

WORKING LINING

MATRIFLO FSM ACX
MATRISIL CV
MATRISIL LC
WAM® AL II
WAM® AL III

LADLES

REPAIR

QUICK-FIRE® ONE PATCH B
QUICK-FIRE® PATCH B
QUICK-FIRE® PATCH M

COATINGS

MATRIKOTE 90 AC
MINRO-Z WASH Z77

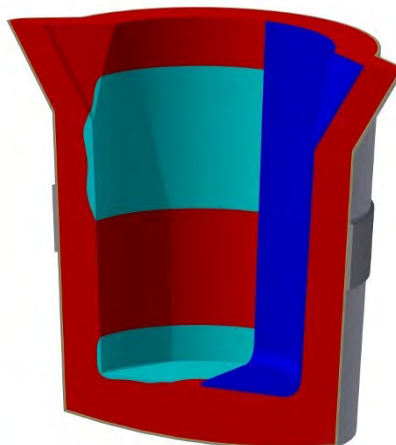

WORKING LINING

BETAMAX® HS LT
MTRICAST 82 SiC
MATRIFLO FSM ACX
QUICK CAST® 61 ACX



process
global
refractory

FLOORING

TUFFLOOR® is designed for areas exposed to extreme thermal cycling and intermittent exposure to liquid metal spills, dross and slag. This product is versatile product and can be installed as a complete floor, over existing (or new) concrete, or as precast tiles. TUFFLOOR® has over 20 years of proven performance in ferrous and non-ferrous foundries, primary metal production facilities (aluminum, steel, iron, zinc, copper, ferro-alloys), rolling mills and many other hot flooring applications.

Benefits include:

- Fast project turn around time with strength development
- Exceeds cold crushing strength of conventional concrete
- Reduced maintenance time and expense
- Safer working surfaces
- Minimized wear on mobile equipment
- Custom colors available
- Excellent freeze-thaw properties



TUFFLOOR® - Headquarters Entrance



Variety of colors available



TUFFLOOR® vs Standard Concrete
Thermal Cycling to 1400°F (760°C)

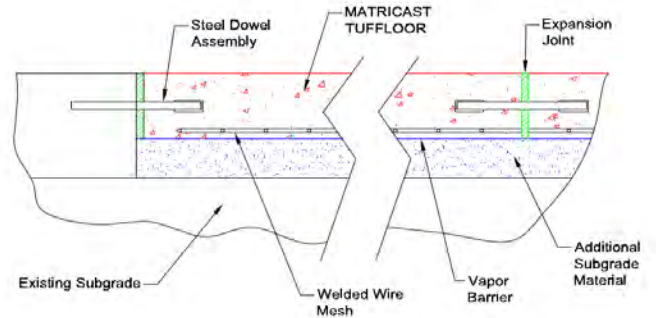

Engineering Design for a High-Load Application





ALUMINUM CONTACT PRODUCT FAMILIES

| | |
|-----------------------------|---|
| DRI-CAST | Dry powder product line, designed for patching fractured / worn refractory. No water required. |
| RAM MAX [®] | Pneumatic rammed plastic |
| REDIGUN | Gunnable plastic for heat and air set |
| MATRIFLO | Specialty line of metal contact castables |
| MATRICAST | Allied's original product line for aluminum, consisting of low cement and high cement castables |
| MATRIGUN / BETAGUN | Gun mixes ranging from super duty to high alumina with non-wetting properties |
| MATRIKOTE | Zircon and high alumina coatings |
| MATRIPHOS | Phosphate bonded plastics containing aluminum non-wetting additive |
| MATRISIL | Fused silica based castables |
| QUICK-FIRE [®] | Two-component, phosphate bonded castables and gunning mixes. Product ranges from 55% - 90% alumina. |
| QUICK-FIRE [®] ONE | Single-component, phosphate bonded castables and gunning mixes |
| QUICK CAST [®] | Aluminum contact and super structure castables using low cement design |
| WAM [®] AL | Light weight, dense, high cement castables and gunning mixes for aluminum contact |
| NANO-TEK [®] AL | No cement castable, may be vibrated, shotcreted, or pumped |
| MATRIPUMP FF | Low cement castable with reduced heat up time |



DRI-CAST 581A



QUICK-FIRE[®]



QUICK-FIRE[®]





TECHNICAL DATA

| Name | Al ₂ O ₃ % | SiO ₂ % | Density | Max. Temp |
|-------------------------------|----------------------------------|--------------------|--|-----------------|
| ARMORMAX [®] 70 SR | 70.1 | 25.5 | 2.66 g/cm ³ (166 lb/ft ³) | 1430°C (2600°F) |
| BETAMAX [®] HS LT | 50.6 | 29.0 | 1.37 g/cm ³ (85 lb/ft ³) | 1290°C (2350°F) |
| BETAMAX [®] 24 LT | 42.4 | 39.7 | 1.23 g/cm ³ (77 lb/ft ³) | 1345°C (2450°F) |
| BETMAX [®] 26 LT | 52.9 | 36.4 | 1.27 g/cm ³ (79 lb/ft ³) | 1425°C (2600°F) |
| COIL-CAST 97A | 96.6 | 0.1 | 3.03 g/cm ³ (189 lb/ft ³) | 1650°C (3000°F) |
| INSULMIX [®] 33100 | 94.5 | 0.4 | 1.60 g/cm ³ (100 lb/ft ³) | 1815°C (3300°F) |
| DRI-CAST 581A | 70 | 15 | 2.64 g/cm ³ (165 lb/ft ³) | 1650°C (3000°F) |
| DRI-LITE [®] 65A-L | 37.6 | 56.0 | 0.96 g/cm ³ (60 lb/ft ³) | 1400°C (2550°F) |
| DRI-LITE [®] 79AL-M | 42.9 | 49.1 | 1.31 g/cm ³ (82 lb/ft ³) | 1370°C (2500°F) |
| DRI-VIBE [®] 520A | 90.7 | 4.5 | 3.04 g/cm ³ (190 lb/ft ³) | 1204°C (2200°F) |
| DRI-VIBE [®] 522A-FR | 80.7 | 8.3 | 2.88 g/cm ³ (180 lb/ft ³) | 1425°C (2600°F) |
| DRI-VIBE [®] 558A-FR | 90.7 | 4.5 | 3.04 g/cm ³ (190 lb/ft ³) | 1095°C (2000°F) |
| GROUT 163 ACF | 91.0 | 3.1 | 2.51 g/cm ³ (160 lb/ft ³) | 1760°C (3200°F) |
| GROUT 563A | 86.1 | 4.8 | 2.72 g/cm ³ (170 lb/ft ³) | 1760°C (3200°F) |
| GROUT 663A | 87.6 | 4.4 | 2.72 g/cm ³ (170 lb/ft ³) | 1760°C (3200°F) |
| KAST TECH [®] 60 | 55.9 | 36.6 | 2.34 g/cm ³ (146 lb/ft ³) | 1649°C (3000°F) |
| LCF 798A | 61.5 | 35.0 | 2.64 g/cm ³ (165 lb/ft ³) | 1705°C (3100°F) |
| MATRICAST 70 AC | 68.7 | 23.7 | 2.58 g/cm ³ (161 lb/ft ³) | 1540°C (2800°F) |
| MATRICAST 2600 AC | 42.7 | 43.4 | 2.03 g/cm ³ (127 lb/ft ³) | 1425°C (2600°F) |
| MATRICAST 3110C | 61.0 | 41.2 | 2.50 g/cm ³ (149 lb/ft ³) | 1705°C (3100°F) |
| MATRICAST SiC | 61.3 | 19.2 | 2.59 g/cm ³ (162 lb/ft ³) | 1760°C (3200°F) |
| MATRIFLO 85 ACX | 84.1 | 7.5 | 2.74 g/cm ³ (171 lb/ft ³) | 1540°C (2800°F) |
| MATRIFLO 93 AC | 84.1 | 0.4 | 3.17 g/cm ³ (198 lb/ft ³) | 1650°C (3000°F) |
| MATRIGUN 25 ACX | 42.0 | 41.7 | 1.95 g/cm ³ (122 lb/ft ³) | 1300°C (2370°F) |
| MATRIKOTE 90 AC | 93.0 | 1.7 | 2.88 g/cm ³ (180 lb/ft ³) | 1650°C (3000°F) |
| MATRIPHOS 85 AC | 80.7 | 12.2 | 2.80 g/cm ³ (175 lb/ft ³) | 1650°C (3000°F) |
| MATRIPUMP AR 61 | 60.8 | 34.2 | 2.47 g/cm ³ (154 lb/ft ³) | 1650°C (3000°F) |
| MATRIPUMP 50 | 53.7 | 40.5 | 2.47 g/cm ³ (154 lb/ft ³) | 1650°C (3000°F) |
| MATRIPUMP 63 ACX | 65.1 | 27.2 | 2.59 g/cm ³ (162 lb/ft ³) | 1540°C (2800°F) |
| MATRIPUMP 70 ACX | 77.5 | 14.4 | 2.74 g/cm ³ (171 lb/ft ³) | 1482°C (2700°F) |
| MATRIPUMP 72 ACX | 78.6 | 15.6 | 2.68 g/cm ³ (167 lb/ft ³) | 1540°C (2800°F) |
| MATRIPUMP 45 AL | 47.0 | 46.9 | 2.35 g/cm ³ (147 lb/ft ³) | 1370°C (2500°F) |
| MATRISIL CV | 20.1 | 66.5 | 2.05 g/cm ³ (128 lb/ft ³) | 1200°C (2200°F) |
| MATRISIL LC | 19.5 | 75.1 | 2.04 g/cm ³ (128 lb/ft ³) | 1370°C (2500°F) |



TECHNICAL DATA

| Name | Al ₂ O ₃ % | SiO ₂ % | Density | Max. Temp |
|--------------------------|----------------------------------|--------------------|--|-----------------|
| MATRISIL SR | 21.6 | 73.7 | 2.05 g/cm ³ (128 lb/ft ³) | 1370°C (2500°F) |
| MINRO-FIRE CAST F80 | 53.2 | 39.3 | 2.24 g/cm ³ (140 lb/ft ³) | 1650°C (3000°F) |
| MINRO-Z WASH Z77* | 1.2 | 35.4 | - | 1650°C (3000°F) |
| NANO-PUMP™ 45 AL HS | 44.6 | 50.4 | 2.08 g/cm ³ (130 lb./ft ³) | 1425°C (2600°F) |
| NANO-GUN™ 45 AL HS | 44.0 | 50.4 | 1.94 g/cm ³ (121 lb./ft ³) | 1540°C (2800°F) |
| NANO-TEK® 60 AL HS | 62.3 | 31.6 | 2.40 g/cm ³ (150 lb./ft ³) | 1500°C (2730°F) |
| NANO-TEK® 65 HS | 60.7 | 35.1 | Vibration: 2.52 g/cm ³ (157 lb/ft ³) Shotcrete: 2.40 g/cm ³ (150 lb/ft ³) | 1705°C (3100°F) |
| NANO-TEK® 70 | 68.1 | 28.6 | Vibration: 2.58 g/cm ³ (161 lb/ft ³) Shotcrete: 2.47 g/cm ³ (154 lb/ft ³) | 1705°C (3100°F) |
| NANO-TEK® 75 18SiC AL HS | 73.9 | 3.7 | 2.93 g/cm ³ (183 lb./ft ³) | 1705°C (3100°F) |
| NANO-TEK® 80 AL HS | 82.4 | 11.1 | 2.72 g/cm ³ (170 lb./ft ³) | 1500°C (2730°F) |
| NANO-GUN™ 84 AL HS | 84.5 | 11.4 | 2.52 g/cm ³ (157 lb./ft ³) | 1760°C (3200°F) |
| PHOS FREE PLASTIC FINE | 88.2 | 10.2 | 2.90 g/cm ³ (181 lb/ft ³) | 1730°C (3150°F) |
| QUICK CAST® 61 ACX | 65.3 | 29.0 | 2.59 g/cm ³ (162 lb/ft ³) | 1540°C (2800°F) |
| QUICK CAST® 62 | 66.1 | 27.2 | 2.64 g/cm ³ (165 lb/ft ³) | 1705°C (3100°F) |
| QUICK CAST® 81 ACX | 76.7 | 18.7 | 2.74 g/cm ³ (171 lb/ft ³) | 1540°C (2800°F) |
| QUICK-FIRE® PATCH B | 78.5 | 10.0 | 2.53 g/cm ³ (158 lb/ft ³) | 1650°C (3000°F) |
| QUICK-FIRE® PATCH M | 62.7 | 26.2 | 2.33 g/cm ³ (145 lb/ft ³) | 1650°C (3000°F) |
| QUICK-FIRE® 88 | 88.2 | 3.9 | 2.84 g/cm ³ (177 lb/ft ³) | 1650°C (3000°F) |
| QUICK-FIRE® 90 | 89.2 | 2.1 | 2.90 g/cm ³ (181 lb/ft ³) | 1700°C (3100°F) |
| QUICK-FIRE® ONE 83 ABR | 82.9 | 3.9 | 2.58 g/cm ³ (161 lb/ft ³) | 1650°C (3000°F) |
| QUICK-FIRE® ONE 84 G | 87.2 | 4.5 | 2.42 g/cm ³ (151 lb/ft ³) | 1600°C (2910°F) |
| QUICK-FIRE® ONE 86 | 86.4 | 4.2 | 2.55 g/cm ³ (159 lb/ft ³) | 1650°C (3000°F) |
| QUICK-FIRE® ONE PATCH B | 79.9 | 10.3 | 2.46 g/cm ³ (153 lb/ft ³) | 1650°C (3000°F) |
| TUFF-FLO 608 | 32.7 | 24.6 | 2.60 g/cm ³ (162 lb/ft ³) | 1650°C (3000°F) |
| RAM MAX® 70 P FINE | 69.1 | 22.8 | 2.44 g/cm ³ (152 lb/ft ³) | 1760°C (3200°F) |
| RAM MAX® 85 P FINE | 81.9 | 11.1 | 2.82 g/cm ³ (177 lb/ft ³) | 1760°C (3200°F) |
| TUFFLOOR® | 35.1 | 42.5 | 2.11 g/cm ³ (132 lb/ft ³) | 1040°C (1900°F) |
| WASH 148A | 91.7 | 5.8 | - | 1700°C (3100°F) |
| WAM® AL II | 61.4 | 0.7 | 1.73 g/cm ³ (108 lb/ft ³) | 1430°C (2600°F) |
| WAM® AL II HD | 77.7 | 0.4 | 2.71 g/cm ³ (169 lb/ft ³) | 1650°C (3000°F) |
| WAM® AL III | 75.5 | 0.4 | 1.76 g/cm ³ (110 lb/ft ³) | 1200°C (2200°F) |
| WAM® AL III HD | 78.1 | 0.4 | 2.66 g/cm ³ (166 lb/ft ³) | 1650°C (3000°F) |
| WAM® AL HDF | 64.3 | 0.4 | 2.46 g/cm ³ (154 lb/ft ³) | 1650°C (3000°F) |



Corporate Headquarters

Columbus, Ohio USA

+1 614-876-0244

info@alliedmin.com

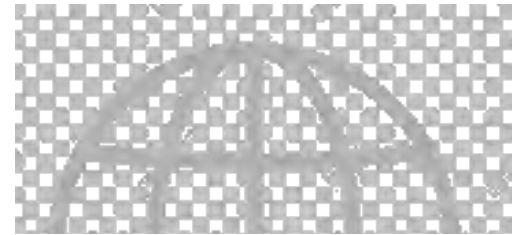

Global **Refractory** Solutions



Scan to view our locations

alliedmineral.com

